

2 1/2" Pitch Hinged Steel Belt Conveyor

Model 2500L

SPECIFICATIONS

Belt:	2 1/2" Pitch Low-Profile belting with welded wing design – custom options available upon request
Belt Widths:	6", 12", 18", 24", 30" & 36" – other widths available upon request
Frame:	6 5/8" height, 12 gauge steel
Belt Speeds:	5, 10, 20, 30, 40 FPM (Feet Per Minute) - other speeds available upon request
Drive HP:	1/4 through 2 H.P.
Drive Styles:	Top, bottom, side and shaft mounted drive packages
Curves:	20°, 25°, 30°, 35°, 40°, 45° or 60°
Optional Features:	Infeed Guides Side Skirts Hoppers Discharge Chutes Top Covers Leg Supports Casters Electrical Controls Cleats Heat Bars Chain Oiler Coolant Tanks Liquid Tight Construction Oilers Belt Brushes Drop Chutes

Typical Cross Section

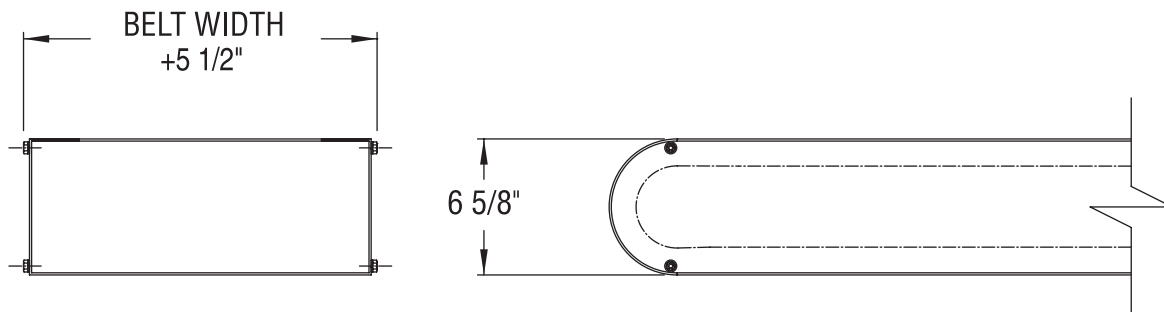

SLIMLINE FRAME (LOW-PROFILE)

*This drawing is for dimensional reference only.
It may not accurately depict the final conveyor design.*

