

2 1/2" Pitch Hinged Steel Belt Conveyor

Model 2500S

SPECIFICATIONS

Belt:	2 1/2" Pitch Slide on Wing Sure-Path belting is standard
Belt Widths:	6", 12", 18", 24", 30", 36"
Frame:	9 5/8" Height, 10 gauge steel - lower frame heights available in low profile and neckdown designs
Drive HP:	1/4 through 2 H.P.
Belt Speeds:	10, 20, 30 FPM (Feet Per Minute)
Drive Styles:	Shaft Mounted, Top Mounted
Curves:	30°, 45°, or 60°
Optional Features:	Infeed Guides Side Skirts Hoppers Discharge Chutes Top Covers Leg Supports Casters Electrical Controls Cleats Flanged Rollers Oilers Belt Brushes Drop Chutes

Typical Cross Section

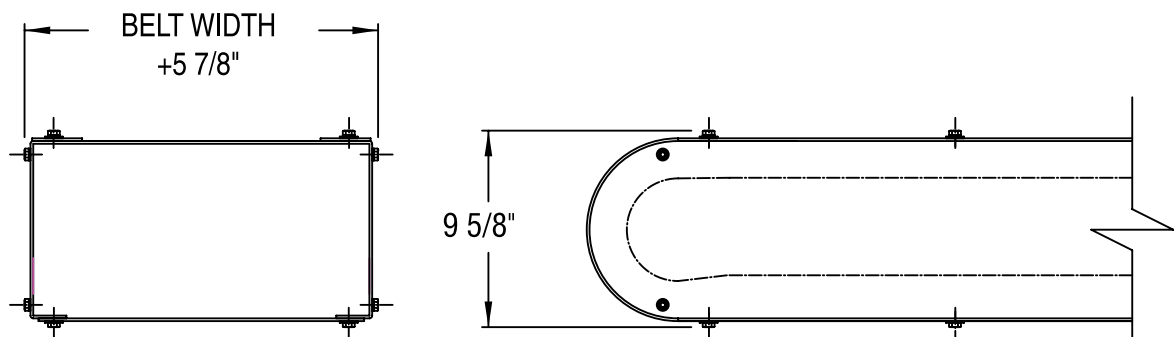

STANDARD FRAME (2500S)

*This drawing is for dimensional reference only.
It may not accurately depict the final conveyor design.*