

4" Pitch Hinged Steel Belt Conveyor

SPECIFICATIONS

Belt:	4" pitch steel belt
Belt Widths:	Standard from 12" to 48" in 6" increments. 12", 18", 24", 30", 36", 42" and 48"
Frame:	Closed style, 10 gauge formed steel
Drives:	Sized to load requirements
Belt Speeds:	5-50 FPM Other speeds available on request.
Curves:	20°, 25°, 30°, 35°, 40°, 45° or 60°
Belt Chain Oiler:	Gravity Drip feed
Optional Features:	Infeed Guides Side Skirts Hoppers Discharge Chutes Top Covers Leg Supports Casters Electrical Controls Cleats Heat Bars Impact Rails Pit Flashing

Typical Cross Section

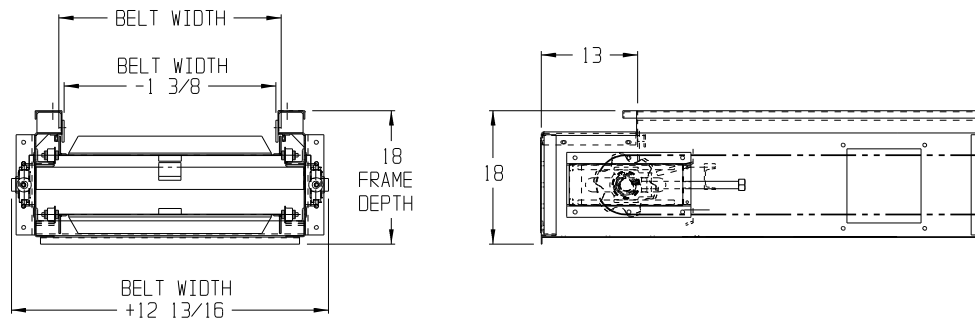

This drawing is for dimensional reference only.
It may not accurately depict the final conveyor design.